

Thank you for selecting our product. Before starting installation, please read this manual thoroughly to ensure correct installation.

Product introduction

- Recessed type door damper completely concealed when the door is closed.
- When installed together with our HES3D concealed hinges, all the hardware is hidden for clean appearance.
- Damper unit will pull and close the door smoothly and firmly right before closing (within about 10°) and prevents slamming.

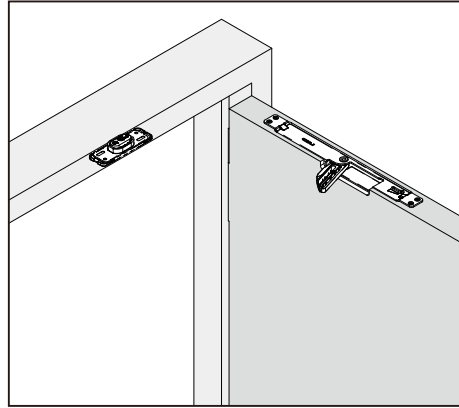

Specifications

Maximum door width	900mm
Door thickness	40 - 60mm
Door weight range	40 - 100kg

● Operating temperature is 0 to 40°C.

Hinge (sold separately)	HES3D-160
	HES3D-E190
	Butt hinge
	Pivot hinge*

*Center hung pivot hinge unusable.

Type	Left-hand opening	Right-hand opening
Item No.	LDD-V100-L	LDD-V100-R

FOR YOUR SAFE WORK AND CORRECT INSTALLATION

Meaning of symbols

- Warning Caution
- Prohibited
- Required

! If these cautions are not followed, it may result in injury or damage.

- ⊘ This product is for indoor use only. Do not use outdoors where the item is exposed to the weather.
- ⊘ Do not use in a windy place as strong wind decreases the damper function.
- ⊘ Do not close the door with excessive force. It may cause damage or defect to soft close mechanism.
- !** Make sure to follow the designated measurements and specifications as well as horizontal and vertical angles. Make sure that the frame is not warped since it may affect the movement of the door.
- !** Make sure that the door and frame have enough durability to withstand the opening and closing force after fabrication.
- !** Make sure to test the screws for slack at regular intervals (one month from first usage, half year and then one time every year is recommended).

Parts List

[The following list indicate the right hand hinge for right side door hang. For left side door hang, a mirror image.]

No.	①	②	③	④	⑤	⑥
Product name	Door damper main unit	Counter plate	Counter plate cover	Body installation screws (nominal 3.5×20)	Attachment jig	Cutout template (door side, frame side)
Parts						
Quantity	1	1	1	8	1	1

Required Tool

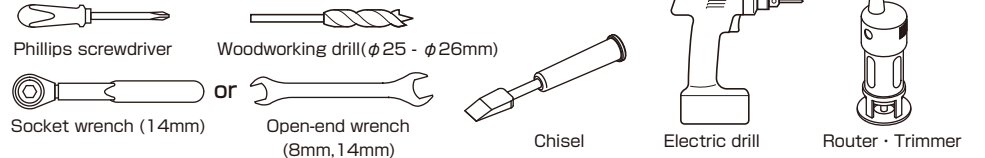

Processing and Installation

[In case not using cutout template, please see P. 7 "Reference : Door and Frame Preparation". The following procedure indicates the right hand hinge. For left side door hang, a mirror image.]

- Place the template to the specified position and mark the line.
 - Align **Butt hinge / HES3D series**
 - Align to rotation center of the hinge. **Pivot hinge (Center hung pivot hinge unusable)**
 - Mark the line
 - To be aligned to the Centerline of door thickness
- Process the door according to the line.
 - Marked part
 - Cutout (Depth 13mm)
 - Mortise cutting (Depth 48mm)
- Process the notch part.

The following procedure should be carried out AFTER the adjustment of hinge and case lock is completed.

- Install the Door Damper. Use provided 3.5×20 screws.
- Fit the jig to the damper unit. Attachment jig.

6 Mark the lines to the upper frame using the attachment jig

· Insert a pencil to the holes, holding the jig firmly

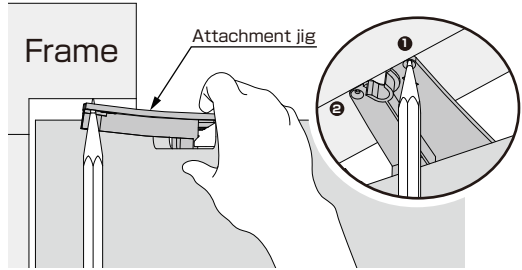

· Move the door and mark the lines.

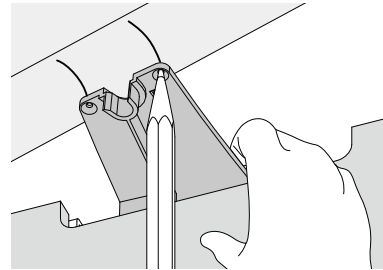

7 Mark the centerline of door thickness

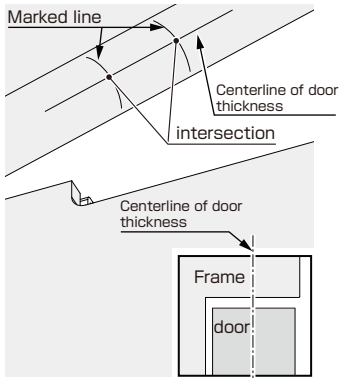

8 Drill 2 holes in the intersection

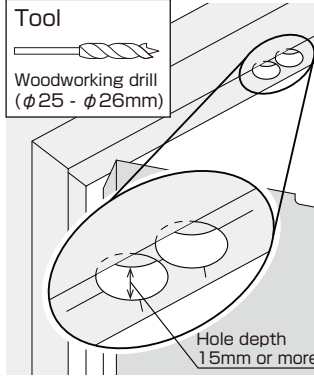

9 Connect the 2 holes into 1 hole

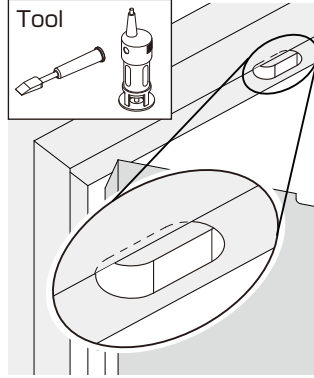

10 Installing the Counter Plate

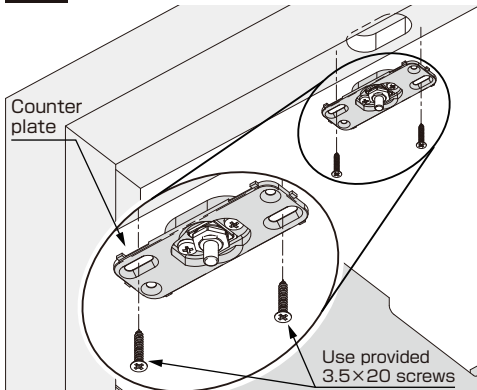

- 1 Pull the Counter Plate over to the door tip side.
- 2 Put the screws through the hinge side of the oval hole.

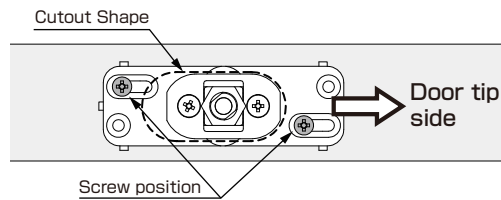

- 3 Adjust the Counter Plate so that the screw position comes to the center of the oval hole.

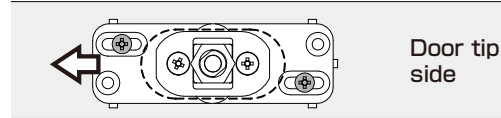

⚠ Do not open or close the door before adjusting the installed counter plate. Operating the door without counter plate adjustment may result in malfunction, causing damage to the damper, door or frame.

Adjustment Procedure

[Confirm to make horizontal/vertical/depth adjustment by following the procedure below.]

Horizontal adjustment

Horizontal adjustment range : $\pm 5\text{mm}$

- 1 Close the door until the shaft and the jig contacts

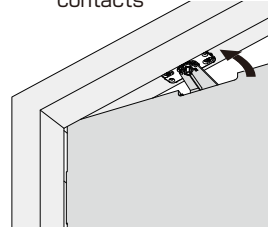

- 2 Position of the Shaft

○ No need to adjust ✕ Adjustment needed ✕ Adjustment needed

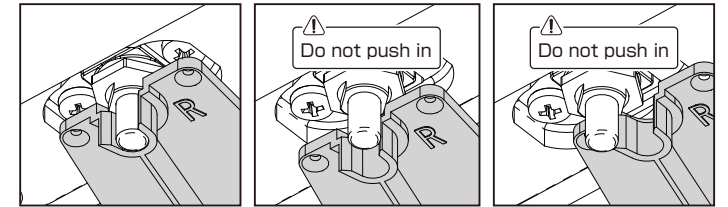

Adjustment method ←

- 3 Loosen the horizontal adjustment screws

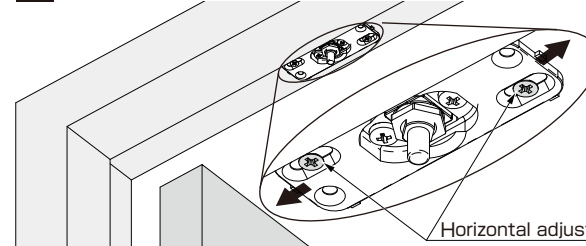

- 4 Counter Plate adjustment

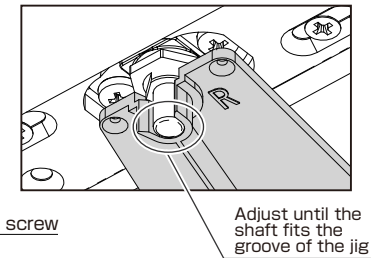

Vertical adjustment

Vertical adjustment range : $+0\text{mm}/-4\text{mm}$ (4mm Downward)

- 1 Position of the Shaft

○ No need to adjust ✕ Adjustment needed

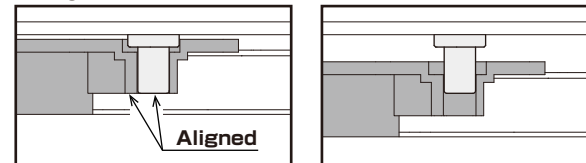

Adjustment method ←

- 2 Loosen the fixing nut of the shaft

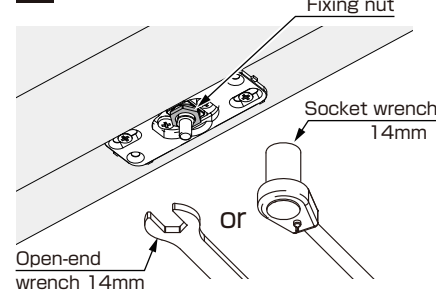

- 3 Counter Plate adjustment

Adjust to the position "○ No need to adjust" shown in Step 1

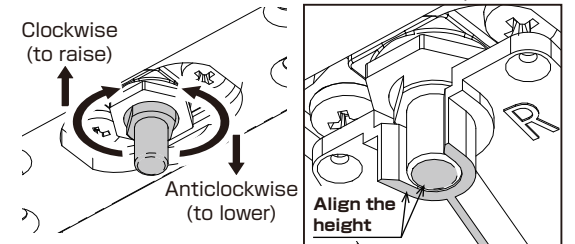

Depth adjustment Depth adjustment range : ±2mm

1 Close the door

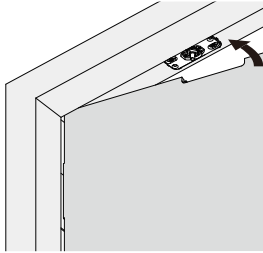

2 Position of the Shaft

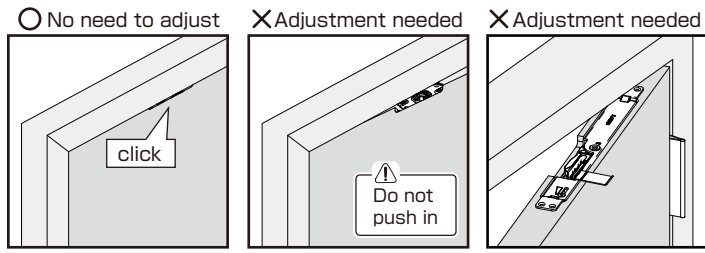

Door does not close Arm remains folded when the door opened

Adjustment method ←

3 Loosen the depth adjustment screws

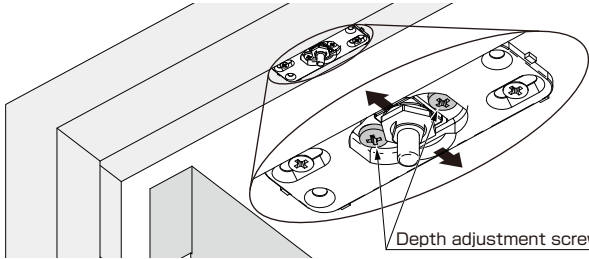

4 Counter Plate adjustment

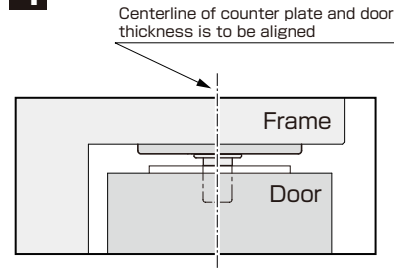

Working after adjustment completed

[The following procedure should be carried out AFTER the shaft adjustment (P.4-5) is completed.]

1 Remove and discard the Reset Plate

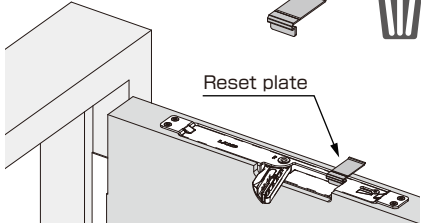

2 Open/Close the door and check the movement

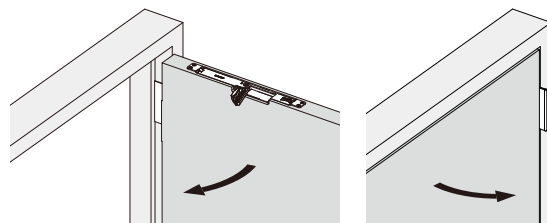

3 Fix the Counter plate firmly with provided 3.5x20 screws

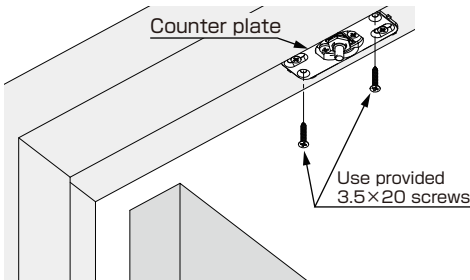

4 Retighten the fixing nut of the shaft

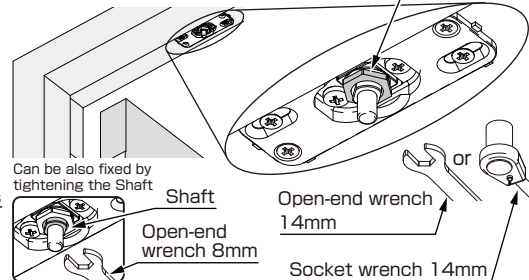

5 Installation of Counter Plate Cover

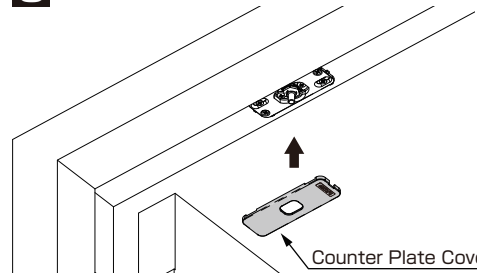

To remove the cover

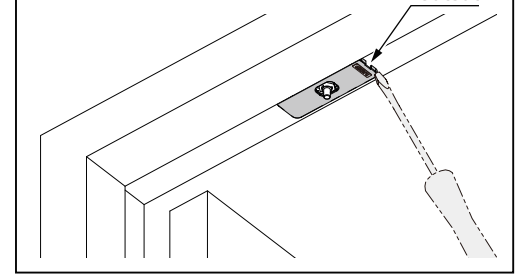

Normal Cut

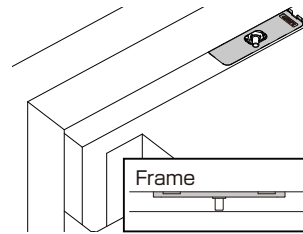

Stepped Cut
(Counter Plate Cover and the Frame become flat)

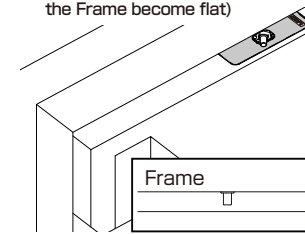

To hide the hole

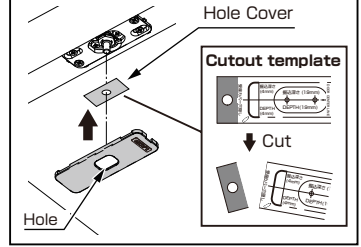

Setting of Damper Force

1 Loosen the Damper Force Adjustment Screw

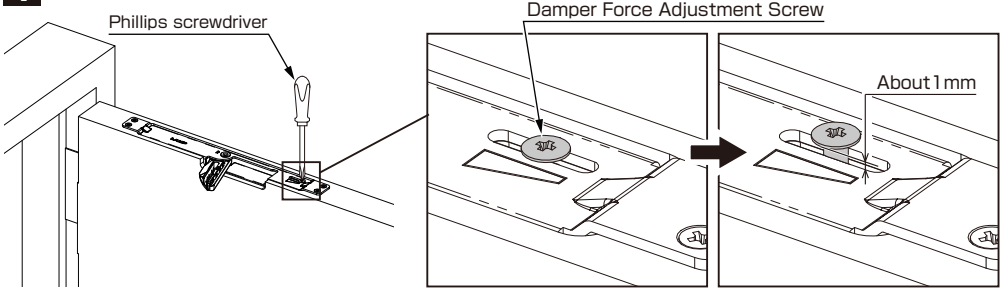

2 Push the screw down and move

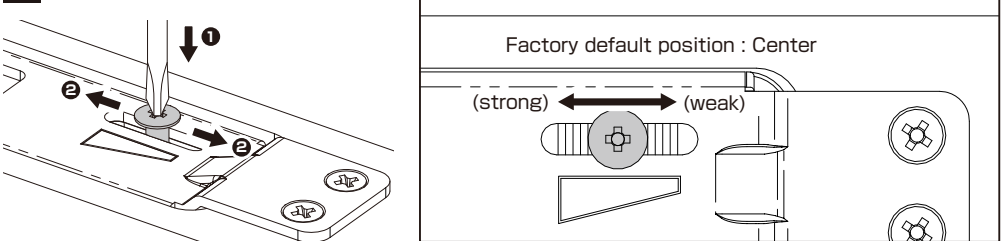

Firmly tighten the Damper Force Adjustment Screw after adjustment completed.

Reference: Door and Frame Preparation

[The following dimensions and procedures indicate the right hand hinge for right side door hang. For left side door hang, a mirror image.]

Preparation for the door

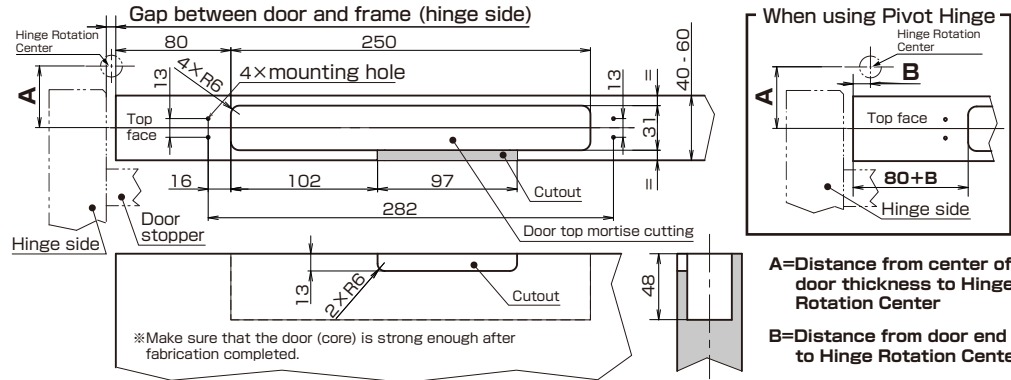

Preparation of frame

Normal Cut (Top gap : 5 - 9 mm)

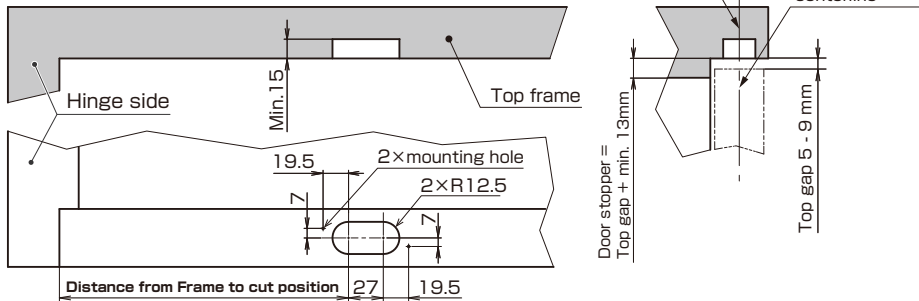

Stepped Cut (Top gap : 3 - 5 mm)

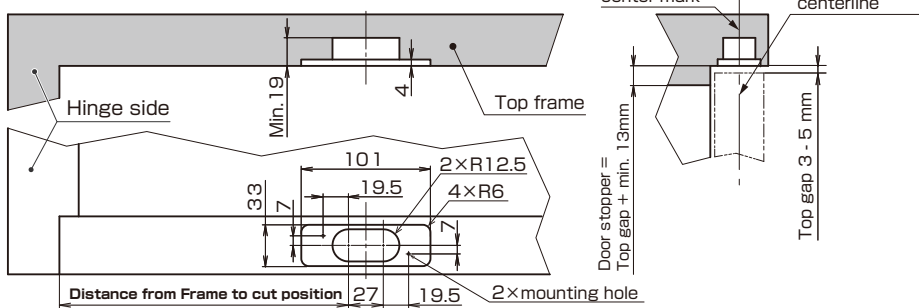

(mm)

※ When the gap between hinge side door and frame is over 5mm, refer to the chart below. (mm)

Hinge	Gap between hinge side door and frame					
	1	2	3	4	5	
HES3D-160, E190	217	218	219	220	221	
Butt hinge	A=20 - 35	220	221	222	223	224
	A=35 - 50	223	224	225	226	227
Pivot hinge	A=20 - 35	220+B	221+B	222+B	223+B	224+B
	A=35 - 50	223+B	224+B	225+B	226+B	227+B

Hinge	Distance from Frame to cut position	
HES3D-160, E190	216 + gap size	
Butt hinge	A=20 - 35	219 + gap size
	A=35 - 50	222 + gap size
Pivot hinge	A=20 - 35	219+B + gap size
	A=35 - 50	222+B + gap size

Trouble shooting

Problem	Cause	Solution
Unusual noise	Mounting position is not correct	Check the mounting position and make adjustments. See P. 7.
	Mortise measures are not correct	Check the mortise dimension and make adjustments. See P. 7.
	Incomplete adjustment	Re-adjust the Horizontal/Vertical /Depth/Damper Force. See P.4-6.
	Counter plate fixation or/and Shaft fixing nut loose	Final tighten the shaft fixing nut after adjustment completed. See P.5 and tighten the nut securely.
Shaft does not enter the groove of the Arm	Improper vertical adjustment (too low)	Vertical adjustment of Shaft is needed. Vertical adjustment range : +0mm/-4mm See P.4.
	Improper horizontal adjustment (one-sided)	Horizontal adjustment of Shaft is needed. Horizontal adjustment range : ±5mm See P.4.
Arm remains folded	Centerline of counter plate and door thickness is not aligned	Depth adjustment of Shaft is needed. Depth adjustment range : ±2mm See P.5.
	Improper depth adjustment	
Door will not close completely	Centerline of counter plate and door thickness is not aligned	Use a suitable door. See P. 1.
	Improper door size	

SUGATSUNE KOGYO CO., LTD
Tokyo, JAPAN
Phone: +81 (0)3 3866 2260 E-mail:export@sugatsune.co.jp

SUGATSUNE SHANGHAI Co., LTD
Shanghai, CHINA
Phone: +86 21 3632 1858 E-mail:lamp@sugatsune.com.cn

SUGATSUNE AMERICA, INC
California, USA
Phone: +1 310 329 6373 E-mail:sales@sugatsune.com

SUGATSUNE KOGYO (UK) LTD
Reading, UK
Phone: +44 118 9272 955 E-mail:sales@sugatsune.co.uk

Guangzhou, CHINA
Phone: +86 20 6639 3552 E-mail:lamp@sugatsune.com.cn

Chicago, USA
Phone: +1 312 461 1081 E-mail:chicago showroom@sugatsune.com

SUGATSUNE EUROPE GmbH
Düsseldorf, GERMANY
Phone: +49 211 538 12900 E-mail:sales@sugatsune.eu

SUGATSUNE KOGYO INDIA PRIVATE LIMITED
Mumbai, INDIA
Phone: +91 22 28314490/91 E-mail:sales@sugatsune.in

SUGATSUNE CANADA, INC.
Mumbai, INDIA
Phone: +1 514 312 5267 E-mail:support@sugatsune.ca

ISO9001(Japan Offices and Sugatsune America) and ISO14001(Chiba Production division and Logistics center), certified.

2017.03 1058-1