

LAMP® HG-TQJ100 ADJUSTABLE ONE WAY TORQUE HINGE Installation Instructions

Motion Designrec®

Thank you for selecting our product. Before starting installation, please read this manual thoroughly to ensure correct installation. Please keep this manual at hand for future reference.

Item Code	Item Name	Torque working Direction	Torque
170-032-969	HG-TQJ100-A	Opening	0-10N·m(0-102kgf·cm)
170-032-970	HG-TQJ100-B	Closing	0-10N·m(0-102kgf·cm)

INSTALLATION PROCEDURE

1. Remove the covers by screw driver.

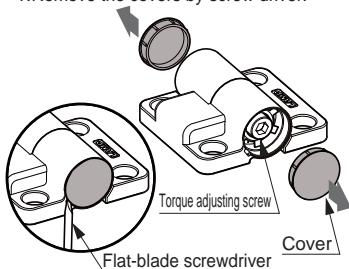

2. Fix hinges with the screws.

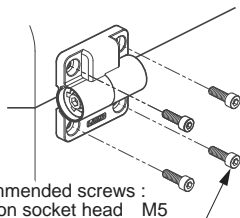

3. Adjust the torque of hinges to work torque effectively.

Please adjust the torque by fixing the screw slotting. It prevents screw idles of torque adjustment screw.

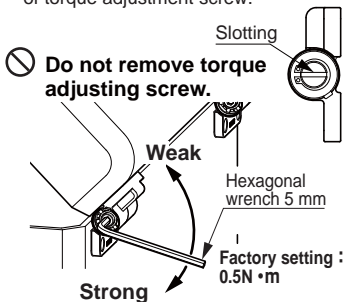

4. Put the covers on the hinges.

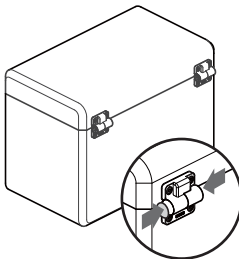

If necessary, re-adjust the torque .

SUGATSUNE KOGYO CO.,LTD
Tokyo, JAPAN
Phone: +81 (0)3 3866 2290 E-mail:export@ Sugatsune.co.jp
SUGATSUNE KOGYO (UK) LTD
Reading, UK
Phone: +44 118 9272 955 E-mail:sales@sugatsune.co.uk
SUGATSUNE EUROPE GmbH
Düsseldorf, GERMANY
Phone: +49 211 53612900 E-mail:sales@sugatsune.eu
ISO9001(Japan Offices and Sugatsune America) and ISO14001(Chiba Production division and Logistics center), certified.

SUGATSUNE SHANGHAI Co., LTD
Shanghai, CHINA
Phone: +86 21 3632 1858 E-mail:tamp@sugatsune.com.cn
Guangzhou, CHINA
Phone: +86 20 6639 3552 E-mail:tamp@sugatsune.com.cn

SUGATSUNE KOGYO INDIA PRIVATE LIMITED
Mumbai, INDIA
Phone: +91 22 28314490/91 E-mail:sales@sugatsune.in

SUGATSUNE AMERICA, INC
California, USA
Phone: +1 310 329 6373 E-mail:sales@sugatsune.com
Chicago, USA
Phone: +1 312 461 1081 E-mail:chicagoshowroom@sugatsune.com

SUGATSUNE CANADA, INC.
Phone: +1 514 312 5267 E-mail:support@sugatsune.ca

2017.08 0950-3